

Kidde ECS Fire Suppression System Component Description



Supervisory Pressure Switch, Explosion Proof
(European Approval)
P/N 06-118398-001

Effective: June 2014
K-90-9051 Rev BA

FEATURES

- ATEX Approved. Ref Directive 94/9EC

DESCRIPTION

The Kidde ECS System cylinder supervisory pressure switch is intended to detect a fall in pressure in the agent cylinder. The cylinder supervisory pressure switch can be wired for either normally open or normally closed operation, depending on installation requirements. This switch can be installed on 3-inch valve cylinders only, i.e., new style 600 lb. cylinders (sold after 8/01) and 900 lb. cylinders.

OPERATION

When the pressure in the agent container drops from the standard charge pressure of 360 PSI (25 bar) to below 288 PSI (19.86 bar) the switch operates. If wired in the NC (open-under-pressure) configuration the resulting pressure drop will cause the contacts to close. When connected to a monitored circuit of a suppression control panel the switching will result in an alarm or trouble condition.

Note: If the temperature of the container contents drop to a temperature of 32°F (0°C) or below, the pressure in the container will be equal to or less than 288 PSI (19.86 bar) and the switch will operate. However, the minimum operating temperature of the system is 32°F (0°C).

INSTALLATION

The supervisory pressure switch can be installed on a fully charged container, without loss of pressure, provided the unit is handled with care and only by trained service personnel. Remove the protective plug in the pressure port fitting by holding the fitting with an 5/8-inch open-end wrench and removing the plug with another wrench. Apply Permacel® #412D Teflon® tape to the male switch threads and while maintaining the wrench on the fitting install the switch. Tighten using a 1-1/16-inch open-end wrench. Leak check using a leak detector or bubbling solution. Secure switch body with wrench when connecting electrical conduit. Isolate the assembly from shock, vibration and areas subject to wide-ranging or rapid temperature fluctuations. Disconnect all supply circuits before wiring the supervisory switch.

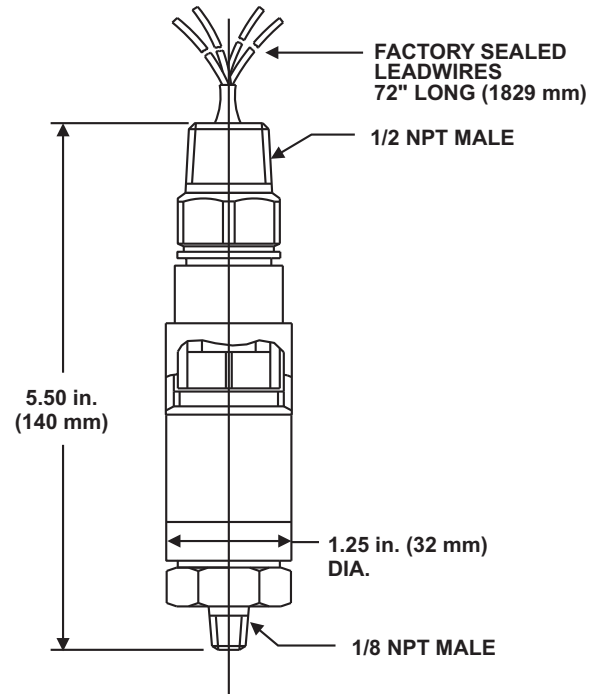

TECHNICAL DATA

- **Approvals:**
 - Cenlec Flame Proof Construction per EExd IIC T6
 - DEMKO A/S Certified to ATEX Directive
 - Flameproof Equipment
- **Enclosure:** NEMA 4X, 7 and 9
- **Switch Output:** One SPDT, Factory Sealed Lead wires
- **Set Point:** 288 PSIG on fall
- **Temperature Rating:** -130°F to 650°F (-90°C to 340°C)
- **Electrical Rating:** 5A @ 250 Vac, Resistive and 3A Inductive @ 28A

COMPATIBILITY

Series	For Use With
Kidde ECS HFC-227ea	X
Kidde ECS Advanced Delivery FM-200®	X

FM-200 is a registered trademark of E.I. du Pont de Nemours and Company. Kidde is a registered trademark of Kidde-Fenwal Inc. All other trademarks are the property of their respective owners.

This literature is provided for informational purposes only. KIDDE-FENWAL, INC. assumes no responsibility for the product's suitability for a particular application. The product must be properly applied to work correctly. If you need more information on this product, or if you have a particular problem or question, contact KIDDE-FENWAL Inc.